

# SOD4001 THRU SOD4007

## SURFACE MOUNT GENERAL RECTIFIER

**Reverse Voltage**  
50 to 1000 Volts  
**Forward Current**  
1.0 Ampere

### FEATURES

- Plastic package has Underwriters Laboratory
- Flammability classification 94V-0 Utilizing Flame
- Retardant Epoxy Molding Compound
- For surface mount applications
- Low leakage current.

### MECHANICAL DATA

- Case: SOD-123, Molded Plastic
- Terminals: Plated Leads Solderable per MIL-STD-202, Method 208
- Polarity: Cathode Band
- Weight: 0.017 grams

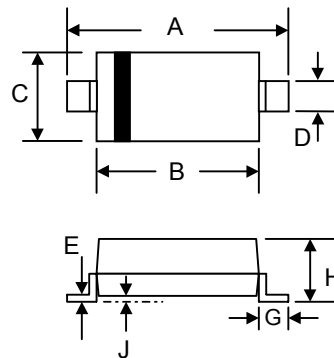

SOD-123		
Dim	Min	Max
A	3.6	3.9
B	2.5	2.8
C	1.4	1.8
D	0.5	0.7
E	—	0.2
G	0.4	—
H	0.95	1.35
J	—	0.12
All Dimensions in mm		

### MAXIMUM RATINGS AND ELECTRICAL CHARACTERISTICS

Ratings at 25°C ambient temperature unless otherwise specified.  
Single phase half-wave 60Hz, resistive or inductive load, for capacitive load current derate by 20%.

PARAMETERS	SYMBOL	PART NUMBERS							UNITS	TESTING CONDITIONS
		SOD 4001	SOD 4002	SOD 4003	SOD 4004	SOD 4005	SOD 4006	SOD 4007		
	Marking Code	A1	A2	A3	A4	A5	A6	A7		
Recurrent Peak Reverse Voltage (Max.)	$V_{RRM}$	50	100	200	400	600	800	1000	V	
RMS Voltage (Max.)	$V_{RMS}$	35	70	140	280	420	560	700	V	
Reverse Voltage (Max.)	$V_R$	50	100	200	400	600	800	1000	V	
Forward Voltage (Max.)	$V_F$	1.10							V	$I_F = 1 A$
Average Forward Rectified Current (Max.)	$I_O$	1.0							A	See Fig.2
Peak Forward Surge Current	$I_{FSM}$	25							A	8.3ms single half sine-wave superimposed on rated load (JEDEC method)
DC Reverse Current at Rated DC Blocking Voltage (Max.)	$I_R$	5.0							$\mu A$	$V_R = V_{RRM}, T_a = 25^\circ C$
		50								$V_R = V_{RRM}, T_a = 125^\circ C$
Junction – Ambient Thermal Resistance (Typ.)	$R_{\theta JA}$	20							$^\circ C/W$	
Junction Capacitance (Typ.)	$C_J$	15							pF	f=1MHz and applied 4V DC reverse voltage
Storage and Operating Temperature Range	$T_{STG}, T_J$	-55 ~ 150, -55 to 150							$^\circ C$	

# SOD4001 THRU SOD4007

## RATINGS AND CHARACTERISTIC CURVES

FIG.1-TYPICAL FORWARD CHARACTERISTICS

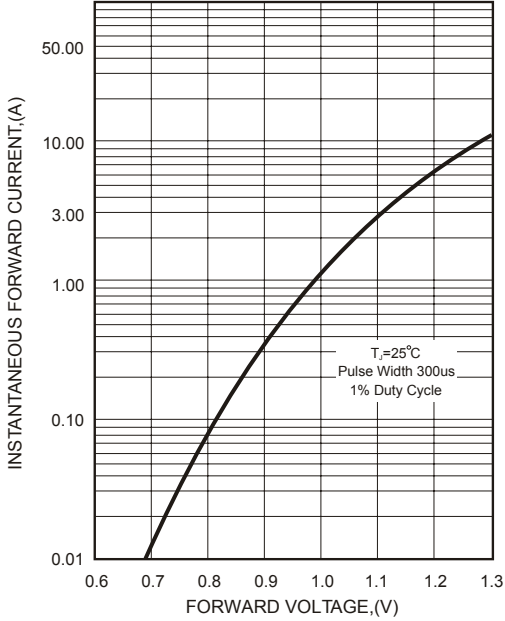

FIG.2-TYPICAL FORWARD CURRENT DERATING CURVE

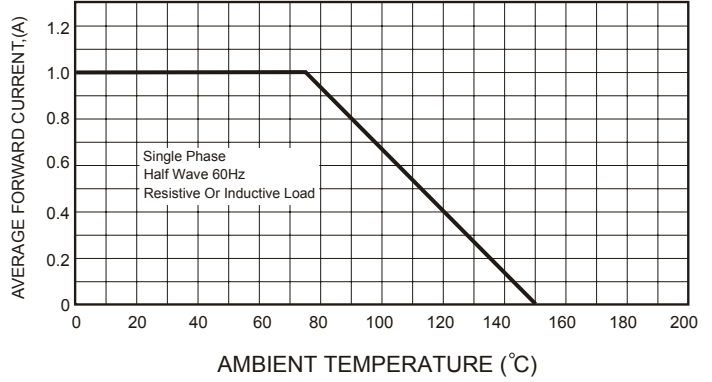

FIG.4-MAXIMUM NON-REPETITIVE FORWARD SURGE CURRENT

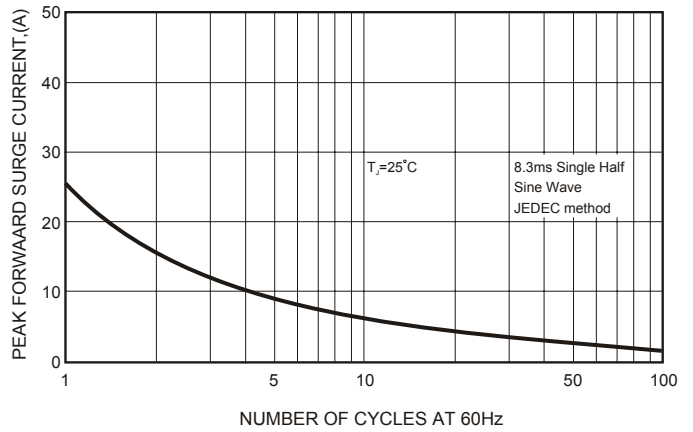

FIG.3 - TYPICAL REVERSE CHARACTERISTICS

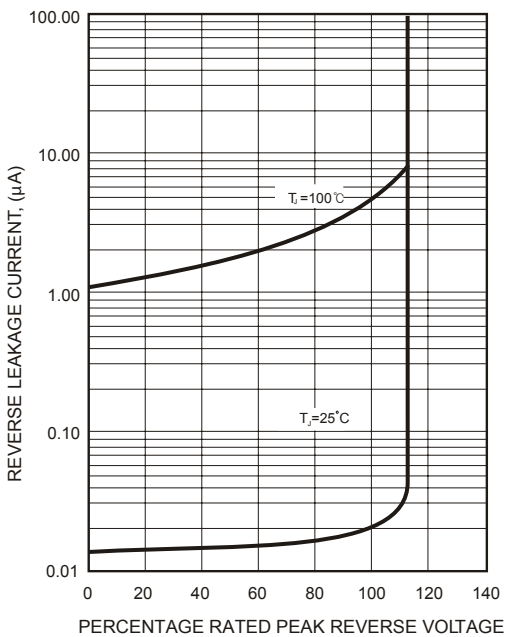

FIG.5-TYPICAL JUNCTION CAPACITANCE

